

# Setup Guide

Snackvendor Models 170/171

12955 Enterprise Way  
Bridgeton, MO 63044-1200  
(314) 298-3510



# Snackvendor Models 170/171 Setup Guide

## TABLE OF CONTENTS

Specifications .....	ii
Electrical Power Requirements .....	1
Unpack the Machine .....	1
Controls and Indicators .....	2
How to Turn the Merchandiser ON and OFF .....	3
Position the Merchandiser .....	3
<b>Snack Section Set-Up .....</b>	<b>4</b>
1. Place a Tray in the Loading Position .....	4
2. Set Up Trays to Vend Products .....	5
Removing a Tray .....	6
Operate a Tray Outside the Machine .....	7
Removing and Installing Spirals .....	8
Installing a Spiral Coupler .....	10
Moving a Tray Up or Down .....	11
Installing a Tray in the Merchandiser .....	12
3. Load Trays with Product .....	13
Product Pusher Usage .....	14
Installing a Product Spacer .....	14
Adjusting a Product Spacer .....	14
Removing a Product Spacer .....	14
4. Return the Trays to the Vending Position .....	15
5. Install Price Tags and Selection ID Labels .....	16
<b>Set Up The Gum and Mint Unit .....</b>	<b>17</b>
1. Install Price Labels .....	17
2. Put the Gum and Mint Dispenser in the Loading Positon .....	17
3. Load the Gum and Mint Dispenser With Product .....	18
4. Return the Gum and Mint Dispenser to the Vending Position .....	19
5. Removing and Installing Column Reducers .....	19
<b>Final Installation .....</b>	<b>20</b>
1. Level the Merchandiser .....	20
2. Install the Base Plate .....	21
3. Install the Lock Cylinder .....	22
4. Install the Optional Cash Box Lock .....	22
5. Install the Optional MDB Harnes .....	23
6. Set Up the Coin Mechanism .....	24
7. Load the Coin Mechanism .....	24

# Snackvendor Models 170/171 Setup Guide

<b>Programming</b> .....	<b>25</b>
Getting Around.....	25
The Displays.....	26
The MODE Switch.....	27
Flowcharts.....	27
Overall Programming Flow Chart.....	28
Configuration Options Flow Chart.....	28
DATA.....	29
PAY OUT.....	29
PRICE.....	29
TEST.....	30
FAULTS.....	30
CONFIGURE.....	31

## SPECIFICATIONS

### DIMENSIONS AND WEIGHTS

MODEL	HEIGHT	WIDTH	DEPTH	SHIPPING WEIGHT
170	183 cm (72 in)	97 cm (38.1 in)	72.4 cm (28.5 in)	
171	183 cm (72 in)	81.3 cm (32 in)	72.4 cm (28.5 in)	

#### CIRCUIT RATING

230 VOLT, 50 HZ MACHINES

MODEL	CURRENT (AMPS)
170/171	

#### CIRCUIT RATING

115 VOLT, 60 HZ MACHINES

MODEL	CURRENT (AMPS)
170/171	

**Operating environment - All models: FOR INDOOR USE ONLY**

#### Ambient Temperature

**Maximum**  
32°C (90°F)

**Minimum**  
5°C (41°F)

# Snackvendor Models 170/171 Setup Guide

## Electrical Power Requirements

The merchandiser is supplied with a service cord for the country of use and is terminated in a grounding type plug. The wall receptacle used for this merchandiser must be properly polarized, grounded, and of the correct voltage. Operating the merchandiser from a source of low voltage will **VOID YOUR WARRANTY**. Each merchandiser should have its own electrical circuit and that circuit should be protected with a circuit breaker or fuse conforming to local regulations.

**Voltage Check** - Place the leads of a voltmeter across the LINE (LIVE) and NEUTRAL terminals of the wall receptacle. The voltmeter should indicate 110-130 volts ac for 120 volt, 60 Hz locations, or 220- 240 volts ac for 230 volt, 50 Hz locations.

**Polarity Check** - Place the leads of a voltmeter across the LINE (LIVE) and GROUND terminals of the wall receptacle. The voltmeter should indicate 110-130 volts ac for 120 volt, 60 Hz locations, or 220- 240 volts ac for 230 volt, 50 Hz locations.

**Noise Potential Check** - Place the test leads of a voltmeter across the NEUTRAL and GROUND terminals of the wall receptacle. The meter should indicate 0 volts ac. A measurement greater than 1.5 - 2.0 volts ac could result in problems for the merchandiser's electronic circuitry caused by electrical noise.

Any deviation from these requirements could result in unreliable performance from your merchandiser.

## Unpack the Machine

Remove all packing materials from the interior of the machine. Keep all documents; warranty cards, etc. Set aside the base plate kit (if present).

# Snackvendor Models 170/171 Setup Guide

## Controls and Indicators

**Message Display.** This is how the merchandiser communicates with the outside world. Customers can see messages about how much money they have put into the merchandiser. The message display also tells customers when a selection is unable to vend. The message display shows you what you are doing when you program the merchandiser, and can show you what is wrong if there is a failure.

**Selection Switch Panel.** The customer uses these switches to make selections. Maintenance people may use this switch panel during programming and other support modes.

**Coin Return Button.** Pressing this button returns any coins that have been paid into the merchandiser prior to a vend.

**Bill Acceptor (Optional).** Accepts bills in various denominations, depending upon the type of bill validator, and how the machine is configured.

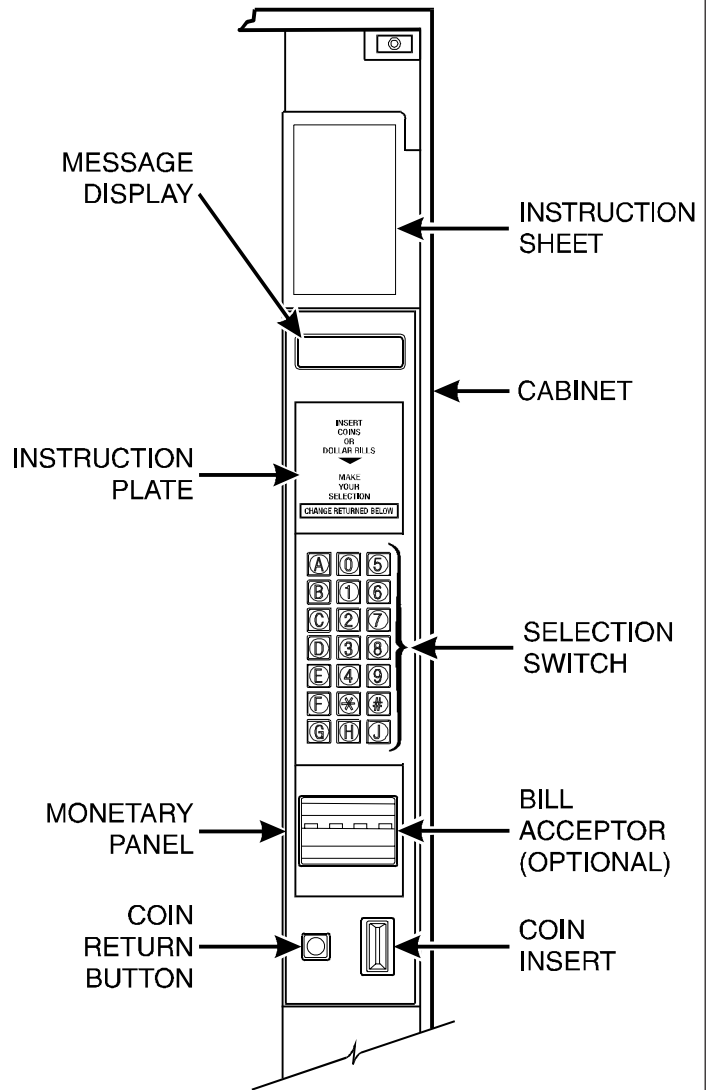

# Snackvendor Models 170/171 Setup Guide

## How to Turn the Merchandiser ON and OFF

### POWER PANEL

- Power to the merchandiser is controlled by the main power switch, located on the power panel.
- The power panel is on the right side of the merchandiser, behind the monetary door.

### WARNING

**⚠ - ELECTRICAL SHOCK HAZARD -** Lethal voltages are present. Unplug the merchandiser whenever you do one of the following tasks. Failure to do so may result in personal injury:

- Change the fluorescent lamp
- Change the lamp starter
- Connect or disconnect a harness (except a motor harness when a tray has been removed)

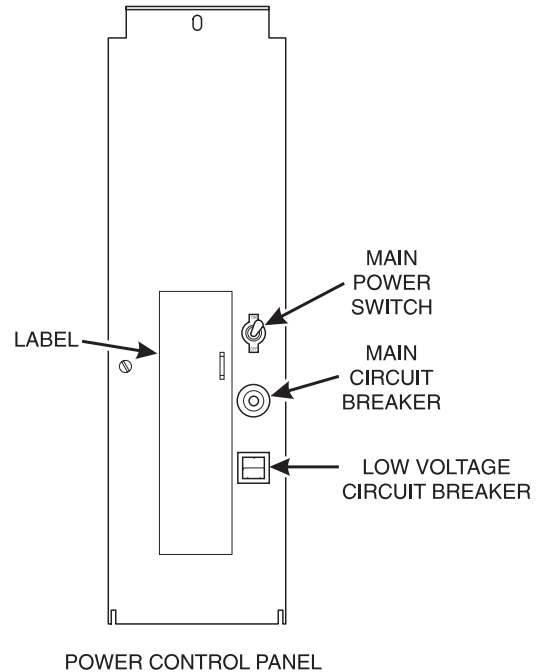

POWER CONTROL PANEL

## Position the Merchandiser

Move the merchandiser to its *approximate* position. (There are some procedures you need to do before it is in its permanent location.) Plug in your merchandiser and turn the power switch to ON.

- You can position this merchandiser anywhere in a bank of machines. It can even be placed on an end flush against a side wall.
- The merchandiser will operate more efficiently when placed in a shaded location.
- There should be enough room in front of the merchandiser for the door to move freely.

### WARNING

This machine is only rated for installation in an indoor location.

## Snackvendor Models 170/171 Setup Guide

# Snack Section Set-Up

### 1. Place A Tray In The Loading Position

1. Place both hands on the tray as shown.
2. Lightly lift the front of the tray and pull the tray toward you until you hear and feel the rear tray rollers drop into the cut-out in the top of the guide rail.

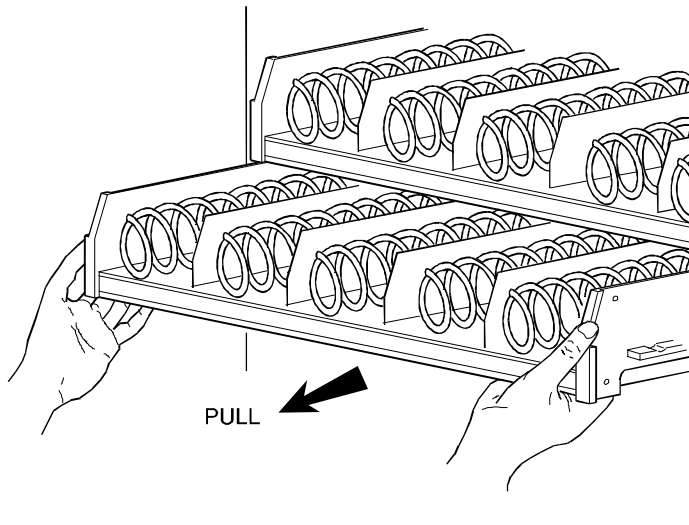

3. Continue pulling the tray forward for another inch. You will then be able to tilt the tray downward into the loading position as shown.

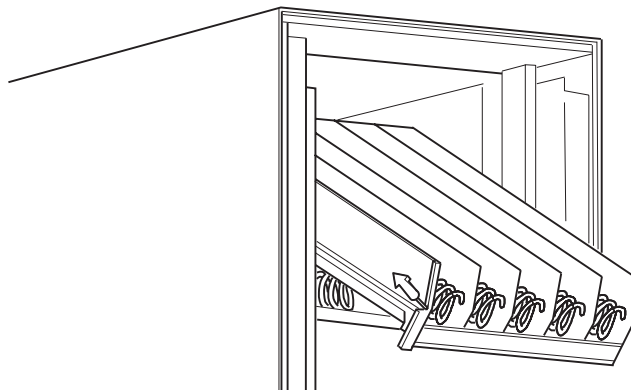

#### NOTE

When the cabinet door is not fully open, the bottom tray will rest on the delivery pan assembly. Handle the tray with care to avoid scratching the delivery pan assembly.



# Snackvendor Models 170/171 Setup Guide

## 2. Set Up Trays to Vend Products

These instructions will guide you through setting up your trays for vending. You will be asked to determine if your tray can physically hold the products you intend to vend. If not, you will be directed to other procedures which will help you get them set up. Follow these nine steps for each tray in your machine:

1. Make sure the tray is in the loading position.
2. Will the products fit between the spiral turns? If so, proceed to the next step. Otherwise, change the spiral.
3. Will the product pass under the tray immediately above? If so, proceed to the next step. Otherwise, reposition the tray and guides.
4. Will the product touch products on either side? If not, proceed to the next step. Otherwise, install a product spacer.
5. Load products in the tray.
6. Return the tray to the vending position.
7. Install the price labels.
8. Install the selection ID numbers.

# Snackvendor Models 170/171 Setup Guide

## Removing a Tray

- Study this procedure before you install a tray for the first time; while you are holding the tray you will not be able to see this area. Proceed as follows:

1. Lightly lift the front of the tray and pull the tray toward you until you hear and feel the rear tray rollers drop into a cut-out in the top of the guide rail.

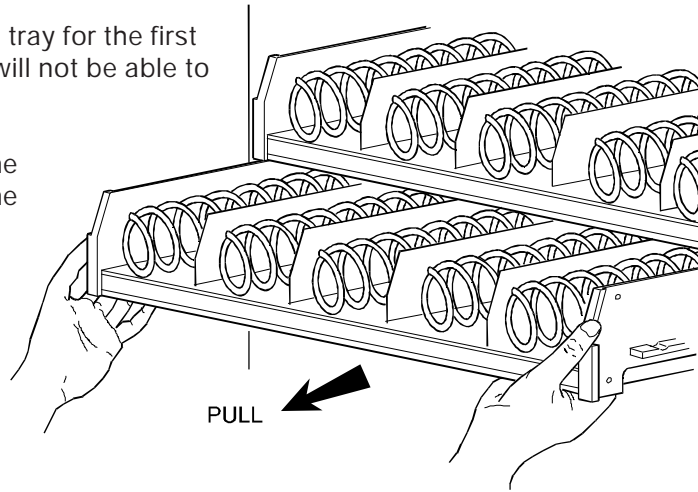
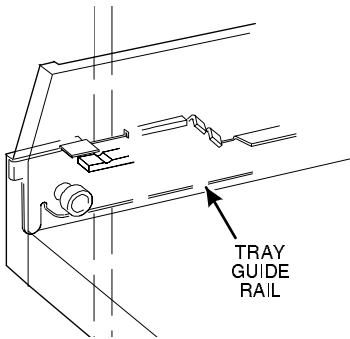

5. Unplug the tray wiring harness from the PC board mounted on the tray guide rail JUST ABOVE the tray you are removing.

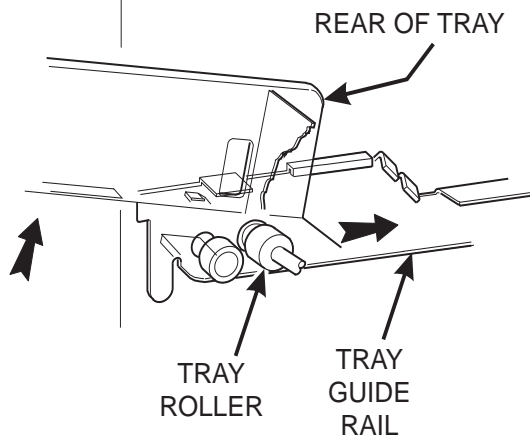
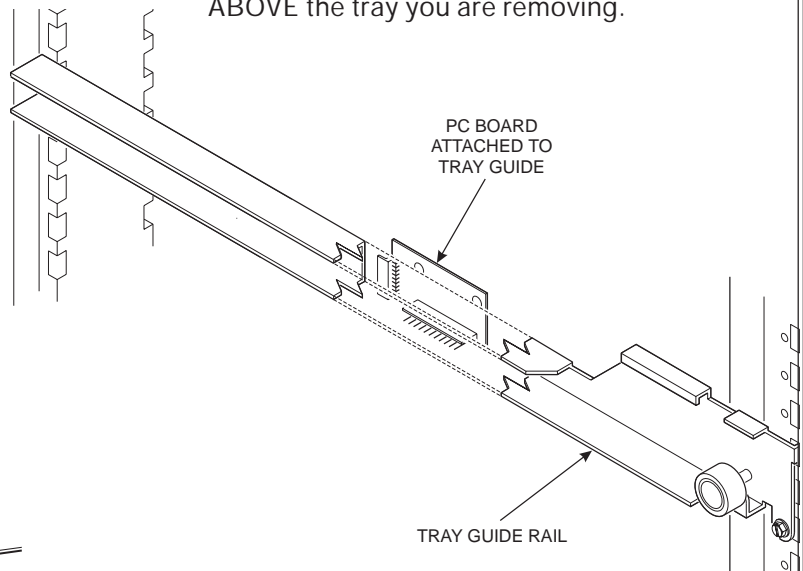

5. Lift up on the tray and slide it toward the back. No more than an inch should be needed.

# Snackvendor Models 170/171 Setup Guide

## Removing a Tray (continued)

6. The tab near the back of the tray should align with the cut-out in the top of the tray guide rail as shown.
7. Lift the tray clear of the tray guide rail and out of the merchandiser.

### CAUTION

When the cabinet door is not fully open, use extra care in removing the bottom tray. Failure to do so may result in damage to the tray or to the delivery pan assembly.

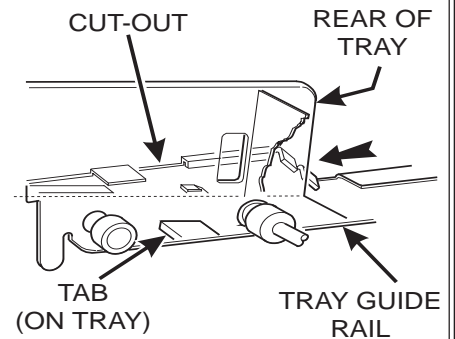

## Operate a Tray Outside the Machine

Tray harness extension (P/N 1709017) is available from your GPL Parts department. The extension will enable you to remove the tray from the machine and still operate the motors and spirals. Connect it as shown:

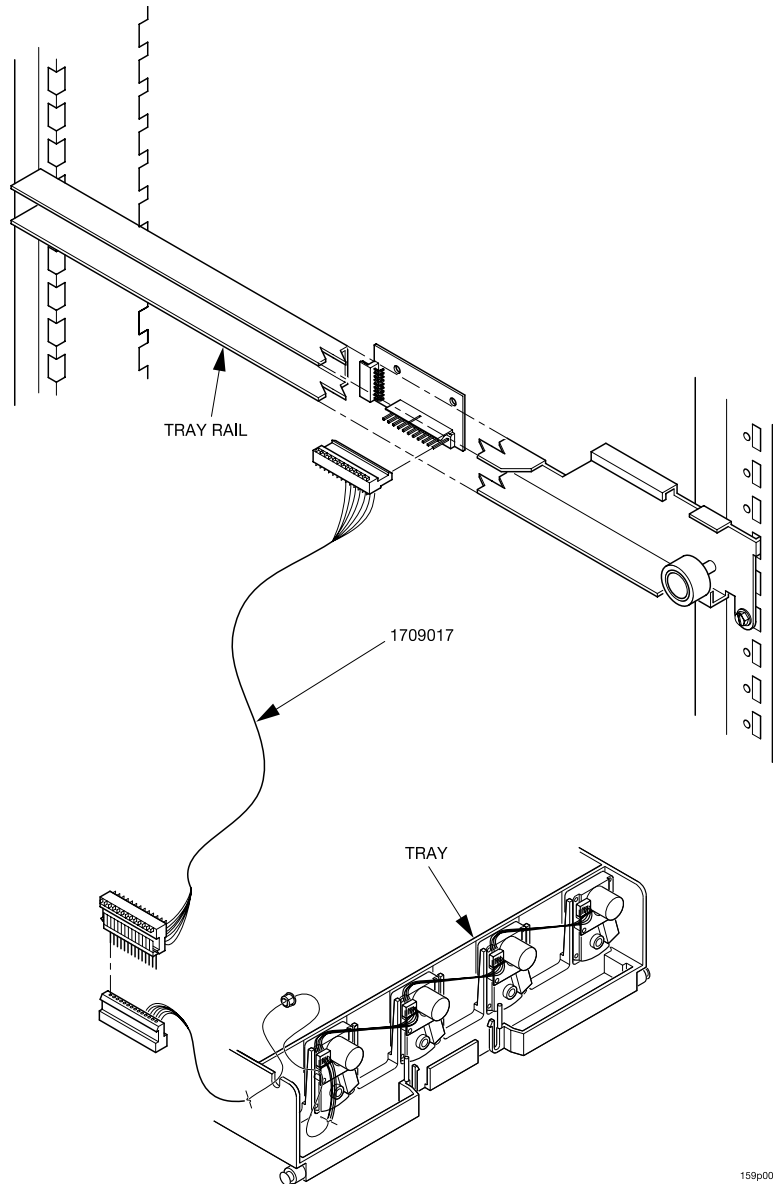

159p0067

# Snackvendor Models 170/171 Setup Guide

## Removing and Installing Spirals

- All candy spirals are the same diameter...

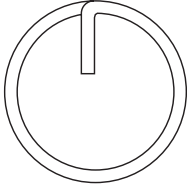

... the pastry spirals are somewhat larger:

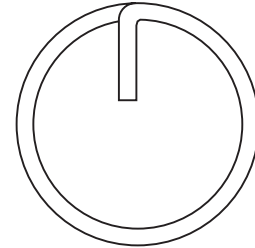

- Pastry spirals all turn in the counter-clockwise direction (left hand), but there are **two** types of candy spirals:

*COUNTER-CLOCKWISE (left hand)*

*CLOCKWISE (right hand)*

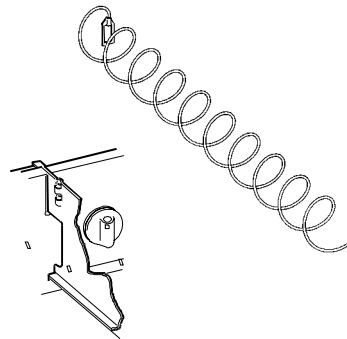
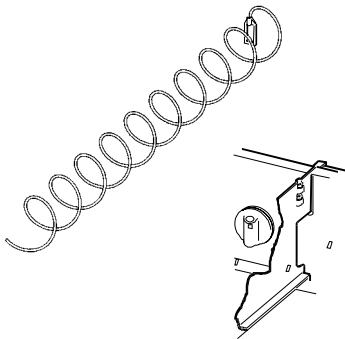

- Each type of spiral is available in three different capacities:

SPIRAL CAPACITY AND ITEM TYPE	PART NUMBER		CLIP COLOR
	COUNTERCLOCKWISE (LH)	CLOCKWISE (RH)	
8 - Pastry	1707024	-	Grey
10 - Pastry	1707026	-	Blue
10 - Candy	1707004	1707006	Blue
12 - Candy	1707008	1707010	Yellow
14 - Pastry	1707028	-	Red
14 - Candy	1707012	1707014	Red

# Snackvendor Models 170/171 Setup Guide

## Removing and Installing Spirals (continued)

### TO REMOVE A SPIRAL:

1. Pull forward on the retaining clip and remove the end of the spiral from the spiral coupler as shown.
2. Remove the spiral from the tray.

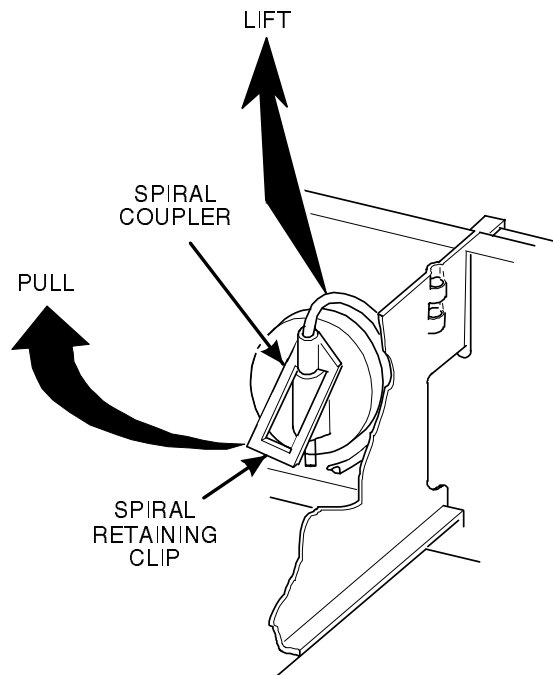

### TO INSTALL A SPIRAL:

1. Pull the bottom of the retaining clip toward the front of the spiral.
2. Lower the spiral into the tray column and insert the end of the spiral into the spiral coupler as shown.
3. Release the retaining clip.

### SHOULD I USE A CLOCKWISE OR A COUNTERCLOCKWISE SPIRAL? (CANDY ONLY)

1. The type of spiral used is determined by the column position it will occupy in the tray.
2. Refer to the figure below to find the correct spiral type.

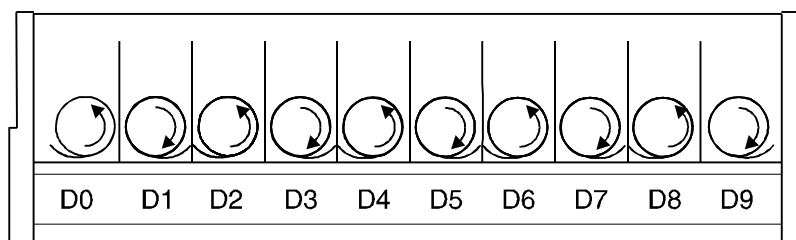

# Snackvendor Models 170/171 Setup Guide

## Installing a Spiral Coupler

Hold the motor in place and push the spiral coupler through the motor gear box until it clicks into position. Be sure the spiral couplers are oriented vertically.

### NOTE

The motor output shaft opening contains eight facets to allow the spiral coupler to be installed in any one of eight positions.

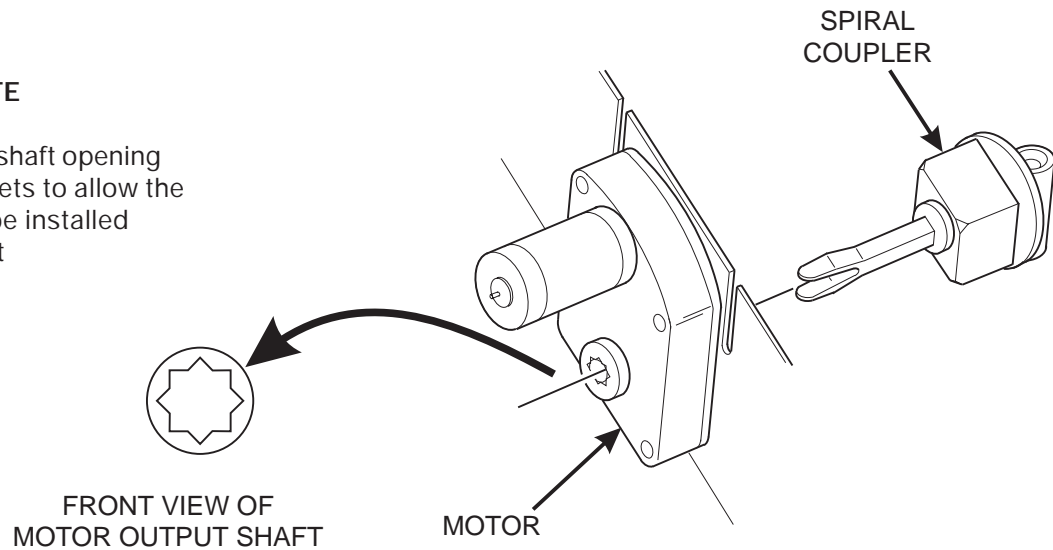

# Snackvendor Models 170/171 Setup Guide

## Moving a Tray Up or Down

This merchandiser can be adjusted to vend taller products. Some guidelines must be followed:

- Keep in mind that when you increase the product height available to a tray by lowering it, you will be decreasing the product height available to the tray below.
- You will need to experiment with various tray positions to get the best results for your products.

### CAUTION

Trays should not be positioned over an open air discharge vent.

### NOTE

Tray movement is limited because the tray harness will limit the amount of travel available to the tray guide rails.

Proceed as follows:

1. Remove the tray from the merchandiser. See **REMOVING A TRAY**.
2. Remove the screw that secures the right tray guide rail to the front guide mounting channel as shown.
3. Tap up on the guide rail and unseat the guide rail tabs from the channel slots.
4. Pull the guide rail away from the front and rear guide mounting channels.
5. Move the guide rail to the desired position.
6. Insert the guide rail tabs into the mounting channel slots as shown.
7. Tap down on the guide rail to seat the tabs in the channel slots.
8. Replace the screw that secures the guide rail to the front guide mounting channel.
9. Repeat steps 2 through 8 for the left guide rail.
10. Return the tray to the merchandiser. See **INSTALLING A TRAY IN THE MERCHANDISER**.
11. Load products into the trays, and perform test vends. Make sure the trays don't interfere with the products you are vending, and that all products vend properly.

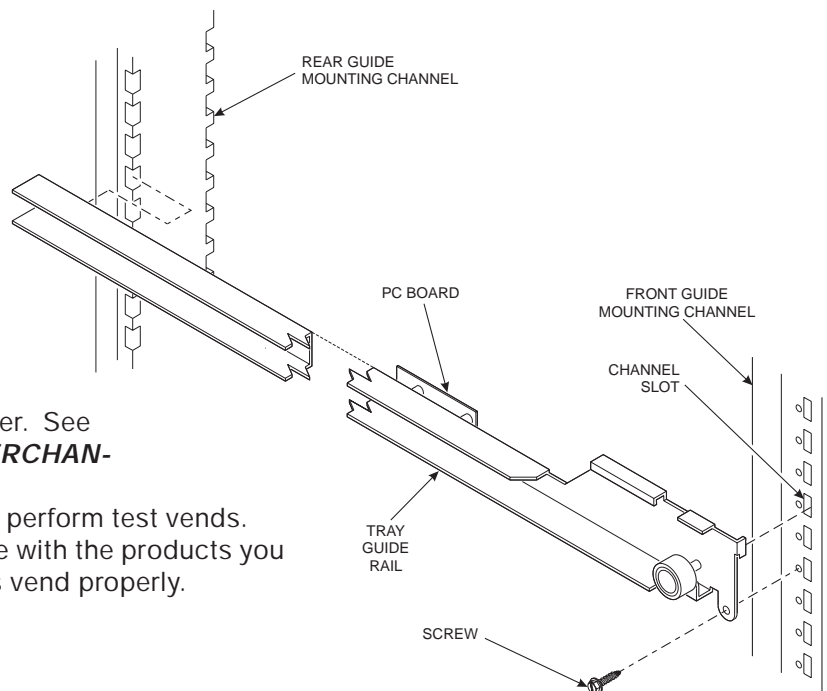

# Snackvendor Models 170/171 Setup Guide

## Installing a Tray in the Merchandiser

- Study this procedure before you install a tray for the first time; while you are holding the tray you will not be able to see this area. Proceed as follows:

1. Insert the tray so that the tray rollers pass over the tray guide rollers.

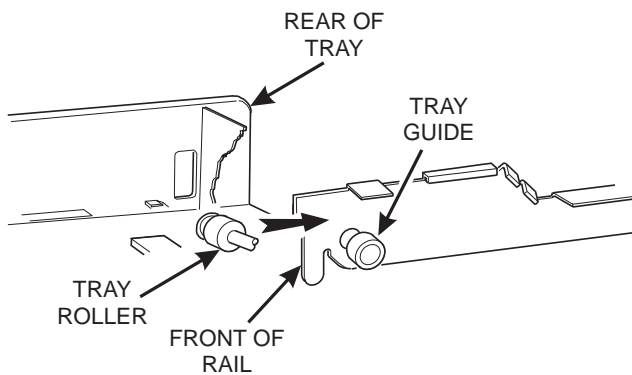

5. Hold the tray up while pushing it toward the rear. Stop when the tab on the tray aligns with the opening in the tray guide.

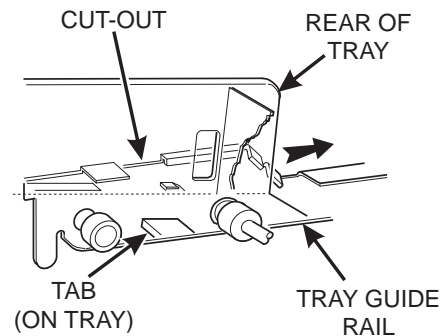

2. Bring the tray roller to rest on the tray guide.

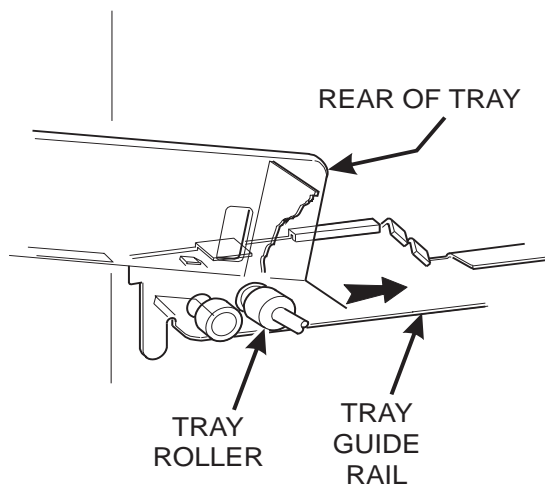

6. Lower the tray until it rests on the tray guide roller. Push the tray in all the way.

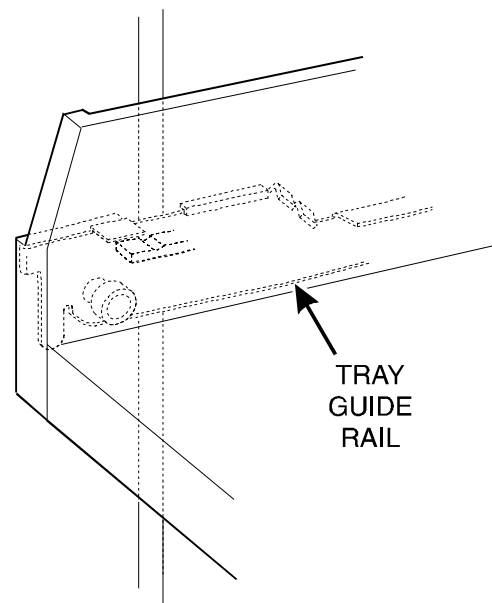

3. Tilt the tray upward.

4. Connect the tray wiring harness to the PC board mounted to the guide rail JUST ABOVE the tray you are installing.



# Snackvendor Models 170/171 Setup Guide

## 3. Load Trays With Product

SPIRAL CAPACITY AND ITEM TYPE	CLIP COLOR	SPIRAL CAPACITY AND ITEM TYPE	CLIP COLOR
8 - Pastry	Grey	12 - Candy	Yellow
10 - Pastry	Blue	14 - Pastry	Red
10 - Candy	Blue	14 - Candy	Red

The color of the spiral coupler (the little plastic tab attached to the rear of the spiral) will tell you how many products will fit in the spiral. See table at left.

### NOTE

Another way to determine spiral capacity is to count the spaces in the spiral !

### LOADING A TRAY WITH PRODUCTS IN GENERAL:

- See **PRODUCT PUSHER USAGE** for spirals with capacity of 10, 12, or 14.
- Begin loading products at the front of the tray and work toward the back. Position the product so the package rests on the tray. **DO NOT** force a product into a spiral.
- If the fit is too tight or too loose, change the spiral size. See **REMOVING AND INSTALLING A SPIRAL**.
- Be sure there are no empty positions between products in each spiral.

### SPECIAL CONSIDERATIONS:

Bagged Products - Position package upright, then push the tops slightly toward the rear of the tray. Also, see **PRODUCT PUSHER USAGE**.

Thin Packages - Position the package upright.

SNACK  
PRODUCT

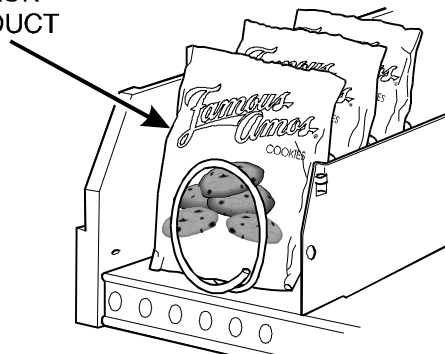

**CORRECT LOADING  
OF SNACKS**

CANDY  
PRODUCT

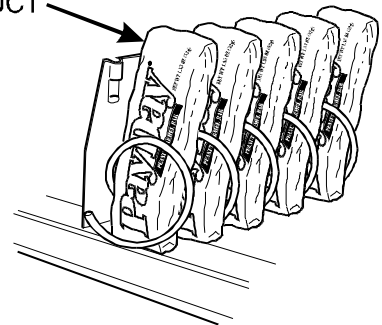

**CORRECT LOADING  
OF CANDY**

# Snackvendor Models 170/171 Setup Guide

## 3. Load Trays With Product (continued)

### PRODUCT PUSHER USAGE (OPTIONAL):

The optional product pusher will give the top of a product an extra tilt to help it fall into the delivery pan.

Use a product pusher in the following cases:

- The spiral has a capacity of 10, 12, or 14.
- The package is non-rigid like bagged peanuts

The product pusher can also be used with other spiral and types of products.

Product pushers are available from the parts department. To use a product pusher, snap it on the spiral as shown. You can adjust the product pusher by moving it around on the spiral to achieve the best vending results.

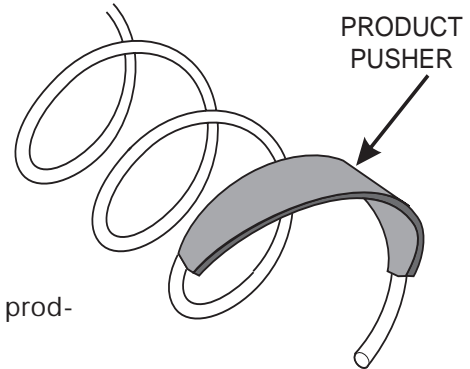

### INSTALLING A PRODUCT SPACER:

The product spacer will keep a tall, narrow product upright.

Insert the product spacer onto the column divider as shown.

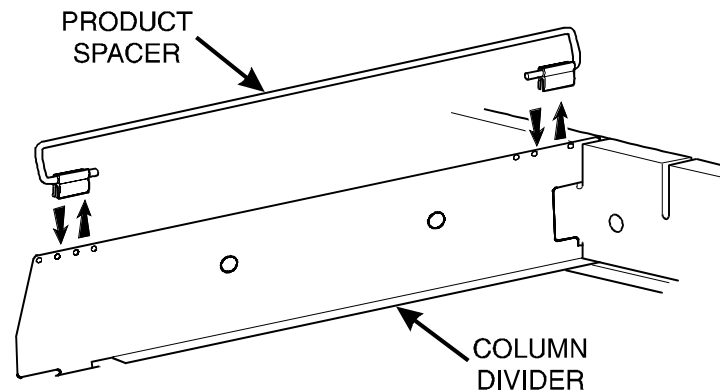

### ADJUSTING A PRODUCT SPACER:

With product loaded in the tray, rotate the product spacer up or down to keep the product upright as shown.

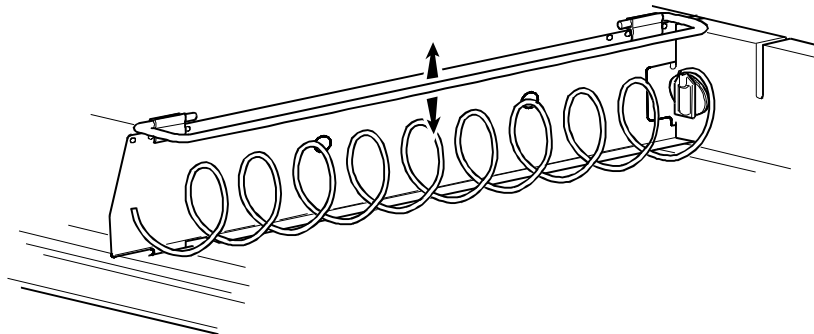

### REMOVING A PRODUCT SPACER:

Pull the product up off the column divider.

# Snackvendor Models 170/171 Setup Guide

## 4. Return the Trays to the Vending Position

1. Lift the tray until it is parallel to the floor as shown.

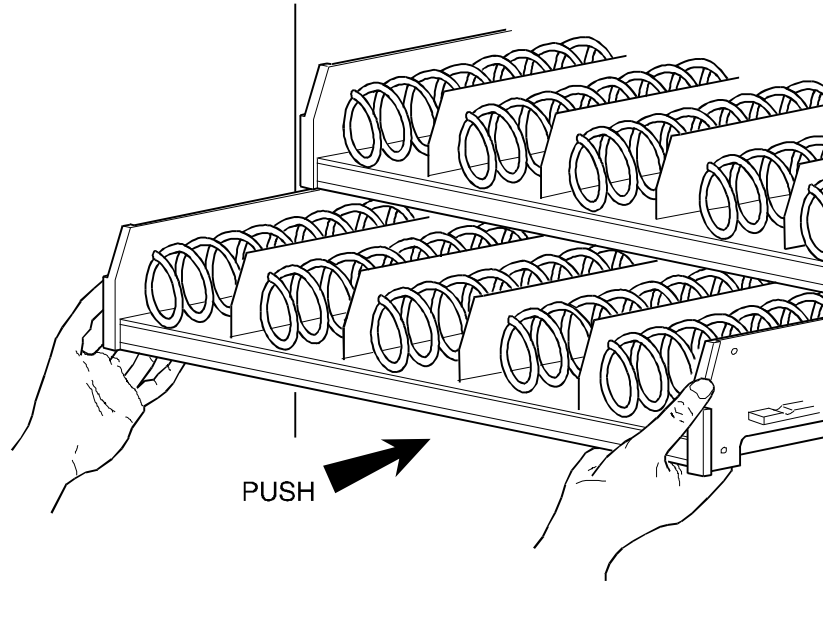

2. Push the tray toward the back of the cabinet.

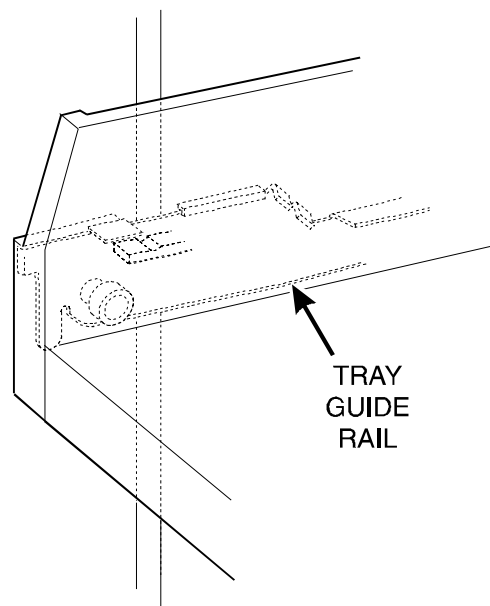

# Snackvendor Models 170/171 Setup Guide

## 5. Install Price Tags and Selection ID Labels

### Price Tags

Price tags are printed on large sheets. You will find these in the plastic bag that contained this manual. Carefully break these apart along the scored lines. Install them as shown.

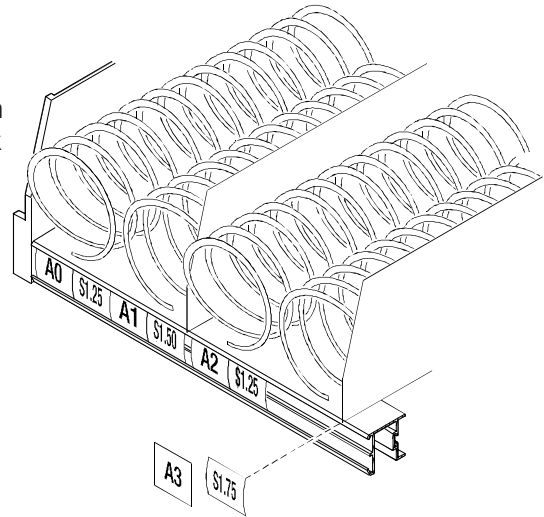

### WHICH ID LABEL GOES WITH WHICH SELECTION?

See the figures below for snack and candy tray positions.

		MOTOR POSITION									
TOP TRAY	TRAY A	A0		A2		A4		A6		A8	
	TRAY B	B0		B2		B4		B6		B8	
	TRAY C	C0		C2		C4		C6		C8	
	TRAY D	D0	D1	D2	D3	D4	D5	D6	D7	D8	D9
	TRAY E	E0	E1	E2	E3	E4	E5	E6	E7	E8	E9
BOTTOM TRAY	TRAY F	F0		F2		F4		F6		F8	
GUM & MINT	TRAY F		F1		F3		F5		F7		F9

EXAMPLE OF A BASIC PASTRY TRAY ID LABEL

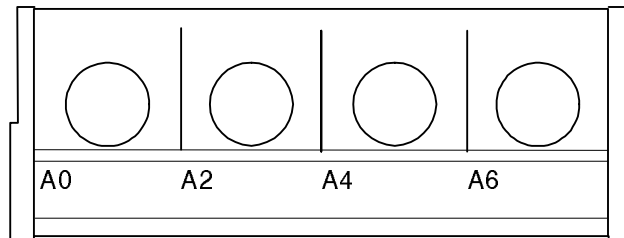

EXAMPLE OF A BASIC CANDY TRAY ID LABEL

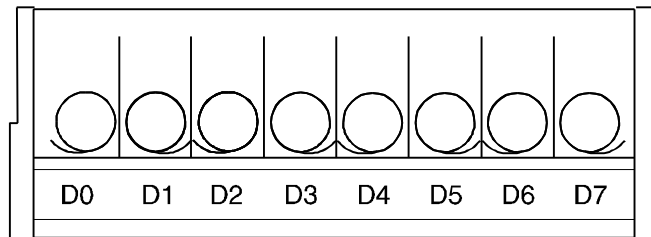

## Snackvendor Models 170/171 Setup Guide

# Set Up The Gum and Mint Unit

### 1. Install Price Labels

The column ID labels have already been attached to the delivery door, and a set of self-adhesive price labels are in the plastic bag that contained this manual.

1. Stick the desired price label next to the column ID number as shown.

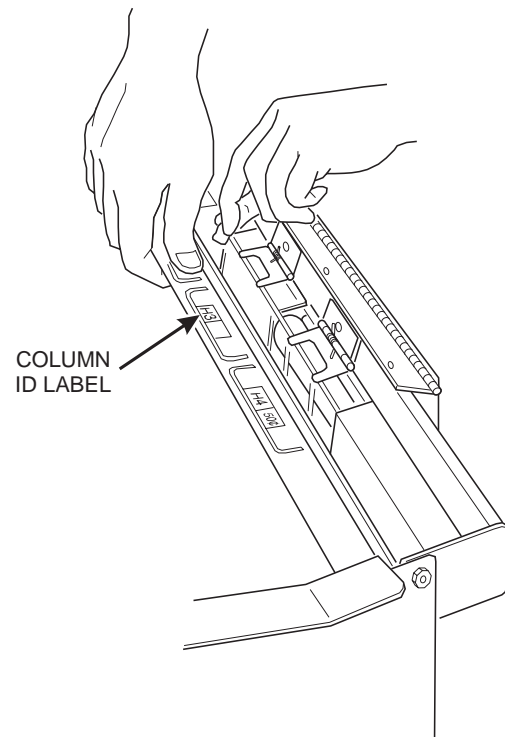

### 2. Put the Gum and Mint Dispenser in the Loading Position

The gum and mint assembly is hinged to the delivery pan assembly and is held in the vending position by two magnets. The gum and mint assembly is held in the loading position by a hook and a loop. One end of the hook is attached to the right side of the door. The loop is mounted on the right side of the gum and mint assembly.

1. Use the loop as a handle and raise the gum and mint magazine with your left hand. With your right hand, move the free end of the hook so it catches the loop. This will hold the magazine while you are loading it with product, as shown.

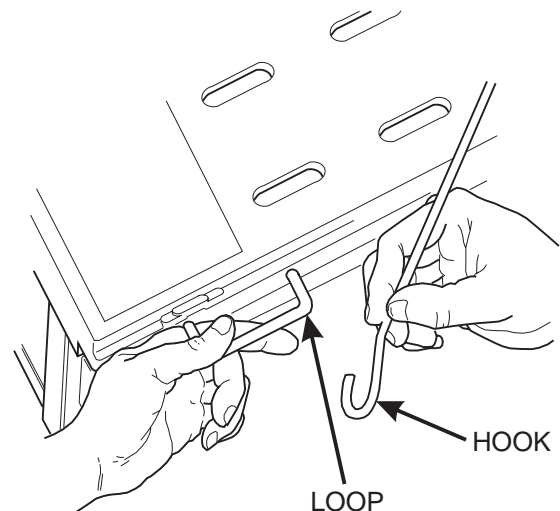

# Snackvendor Models 170/171 Setup Guide

## 3. Load the Gum and Mint Dispenser With Product

1. The gum and mint assembly lid is held closed by two magnets. Open the lid toward the inside of the merchandiser door.

### WARNING

Keep your hand on the product pusher until it is locked in place. Failure to do so may result in personal injury or in damage to the dispenser.

2. Move the product pusher into the loading position:
  - a. Pull back on the pusher.
  - b. Pull down on the pusher and lock the front glide into position.

3. Load the product:
  - a. Push the product forward.
  - b. Be sure the last item is completely under the product retaining lip.

### WARNING

Keep your hand on the product pusher until it comes to rest behind the last item in the column. Failure to do so may result in personal injury or in damage to the dispenser.

4. Move the product pusher into the dispensing position:
  - a. Pull the product pusher down to unlock the front glide.
  - b. Slide the product pusher toward the product.

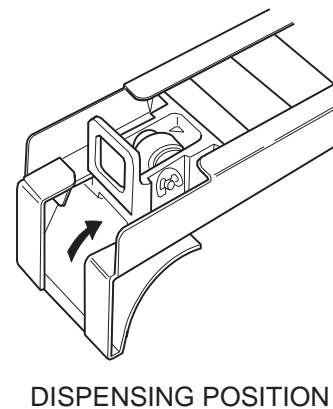
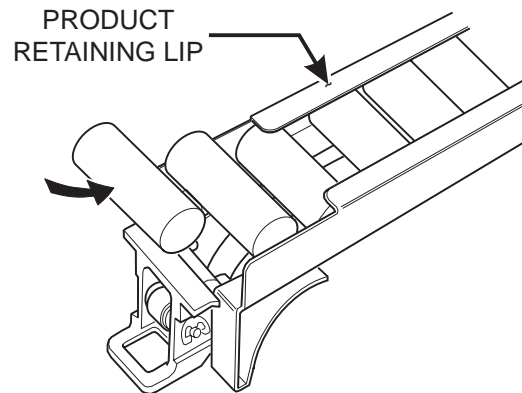
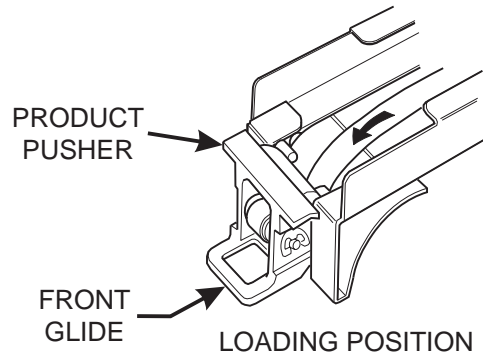

# Snackvendor Models 170/171 Setup Guide

## 4. Return the Gum and Mint Dispenser to the Vending Position

1. Make sure all product pushers are in the vending position.
2. Close the gum and mint assembly lid.
3. Hold the loop on the right side of the magazine with your left hand. Release the hook with your right hand and lower the magazine.
4. Continue to hold the loop until the magazine has been fully lowered.
5. Pivot the gum and mint assembly back to the vending position.

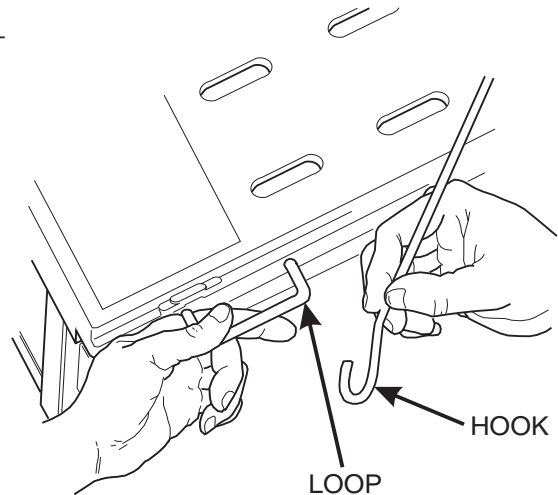

## 5. Removing and Installing Column Reducers

The two left-most vending columns (as seen from the loading side) can be adjusted for two different widths.

When a column reducer is in place, the width of the column will be  $3\frac{1}{16}$  inches.

When a column reducer is removed, the width of the column will be  $3\frac{7}{8}$  inches.

### TO REMOVE A COLUMN REDUCER:

1. Pull the reducer away from the cabinet door to disengage the locking tabs.
2. Lift up to remove the reducer from the gum and mint assembly.

### TO INSTALL A COLUMN REDUCER:

1. Place the reducer on the gum and mint dispenser so the locking tabs are in the slots.
2. Push the reducer toward the cabinet door to lock the reducer in place.

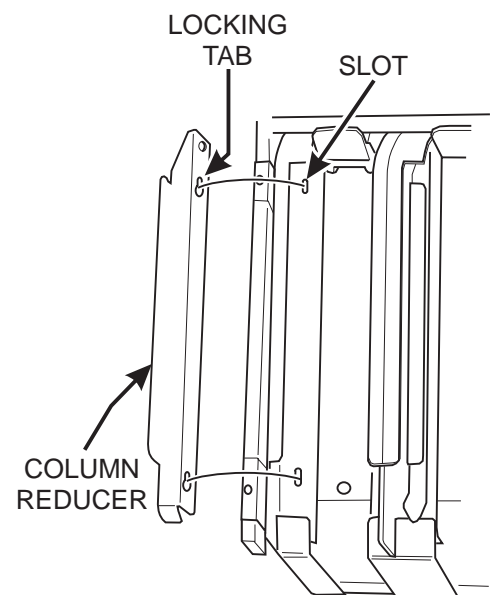

# Snackvendor Models 170/171 Setup Guide

## Final Installation

Some machines have a small square rear duct that must be installed before the machine is moved into its final position. If your machine has this duct, locate it and follow the enclosed instructions.

Move the merchandiser to its *final* position:

- You can position this merchandiser anywhere in a bank of machines. It can even be placed on an end flush against a side wall.
- There should be enough room in front of the merchandiser for the door to move freely.

### WARNING

This machine is only rated for installation in an indoor location.

## 1. Level the Merchandiser

1. Place a spirit level on the top front edge of the cabinet with the door fully closed. Adjust the front legs only until the cabinet is reasonably level (figure 1).
2. Hold the door open about 4 inches. (This relieves any stress the door may be placing on the cabinet.)

### WARNING

Have an assistant hold the merchandiser while you adjust the leg levelers.

3. Adjust the back legs so that the back leg leveler on the hinge side is off the floor just enough so a piece of paper can slide under it with only a bit of resistance (figure 2).
4. For proper weight distribution on all four legs, raise the back leg on the hinge side by unscrewing the leveler 1½ turns.

### NOTE

You may need to use pliers or channel locks to loosen the leg levelers.

When the merchandiser is part of a bank of machines, level it in reference to the other machines. After leveling is complete, check that the door operates easily.

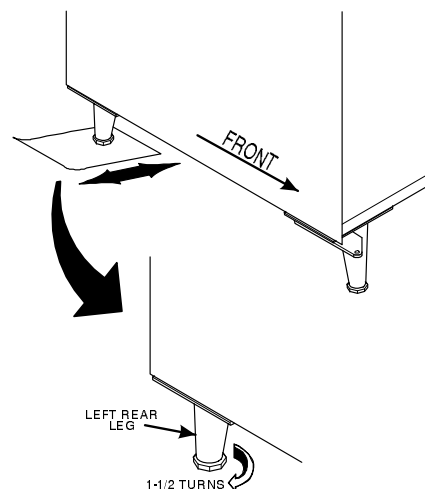
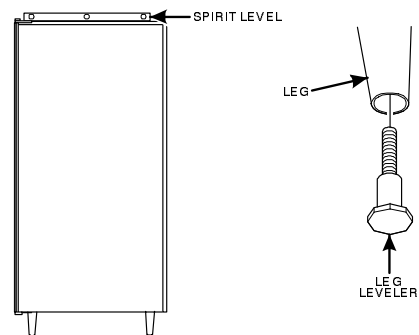



# Snackvendor Models 170/171 Setup Guide

## 2. Install the Base Plate

Refer to the figure below while completing the following procedures:

### WARNING

**Do not move the cabinet while the hex head screws and/or carriage bolts are loosened. The cabinet would become unstable and likely to tip and cause injury.**

1. Remove the waste pail and the grounds pail from the merchandiser (refreshment center only).
2. Remove the floor liner from the merchandiser (refreshment center only).
3. Remove the two caps as shown.
4. Loosen the left leg assembly carriage bolts and nuts to allow mounting a base plate bracket.
5. Secure one of the base plate brackets to the leg assembly using the two carriage bolts. Tighten the carriage bolts and nuts.
6. Loosen the right leg assembly hex screws to allow mounting the other base plate bracket.
7. Secure the other base plate bracket to the right leg assembly using the two hex head screws. Tighten the hex head screws.
8. Insert the short arms of the slides into the hinged tabs of the base plate. Position the slide so the notch near the short arm is on the bottom side.
9. Insert the long arms of the slides into the base plate brackets.
10. Insert and secure a cotter pin through the hole in the back of each of the slides.
11. Push the base plate toward the merchandiser cabinet. The front tabs of the base plate brackets should seat in the notches in the long arms of the slides.
12. Replace the caps, liner, and pail(s) removed previously.

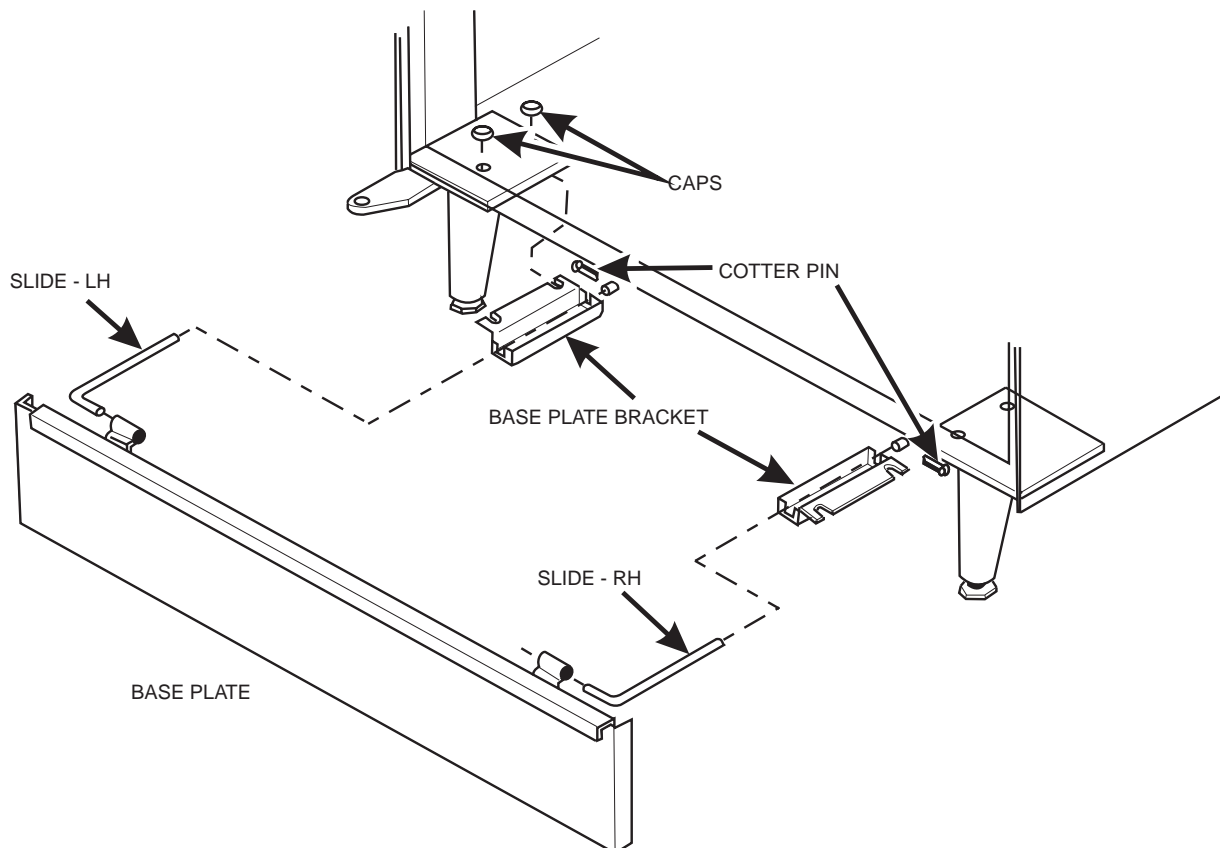

# Snackvendor Models 170/171 Setup Guide

## 3. Install the Lock Cylinder

Install an optional lock cylinder in the merchandiser as follows:

1. Position the lift handle lock lever as shown.
2. Depress the lock spring at the square hole of the lock cylinder receptacle and pull the lock springs out through the front.
3. Position the lock cylinder as shown. Depress the spring loaded lock pin.
4. Push the cylinder into the cylinder receptacle in the lever. The pin should snap into the square hole.
5. If the cylinder pin does not seat in the square hole, press against both ends of the lock cylinder. Rotate the cylinder until the pin snaps into place.
6. **Leaving the door open**, test the lock mechanism with a key.

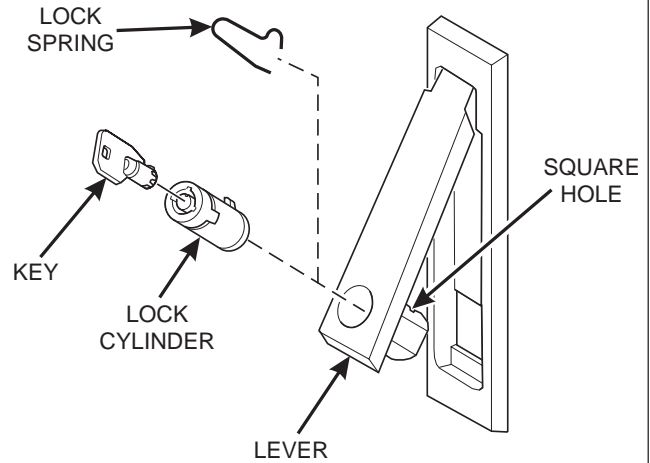

## 4. Install the Optional Cash Box Lock

1. Remove the cash box from the merchandiser.
2. Assemble the lock as shown in the illustration to the right.
3. Return the cash box to the merchandiser.

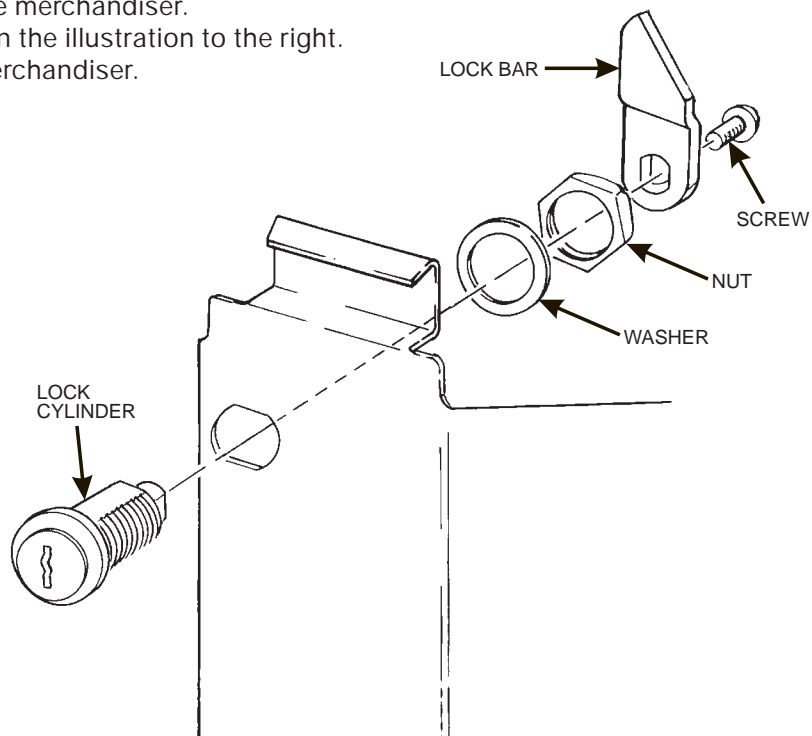

# Snackvendor Models 170/171 Setup Guide

## 5. Install the Optional MDB Harness

Some MDB capable Bill Validators are supplied from the manufacturer without the Bill Validator MDB harness (item 1 in figure below). This harness must be added for MDB operation. The table lists the part numbers for the required harness. In addition to buying the cables from the Validator manufacturer, some cables can also be purchased from National Vendors.

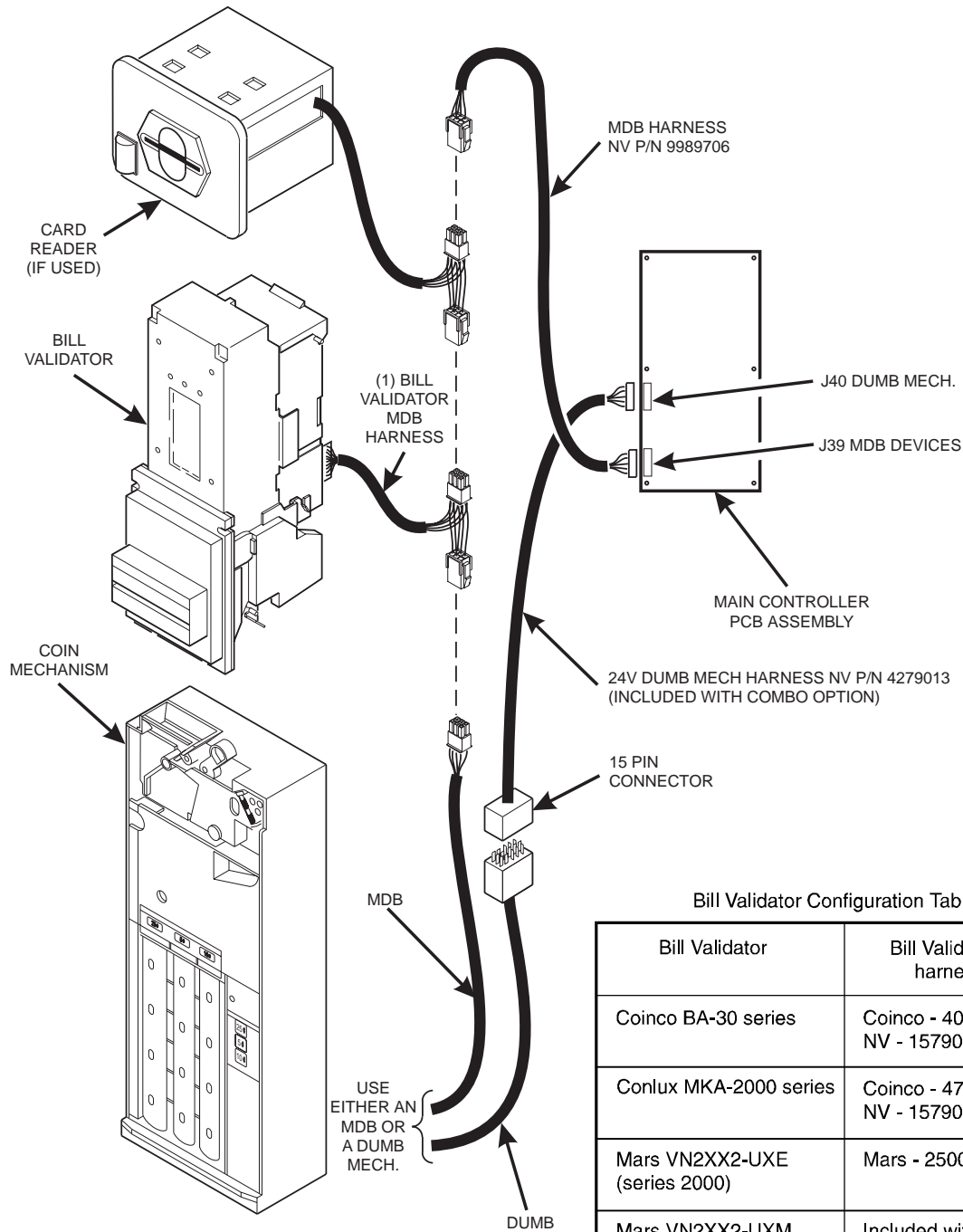

Bill Validator Configuration Table.

Bill Validator	Bill Validator MDB harness P/N
Coinco BA-30 series	Coinco - 407420 NV - 1579034
Conlux MKA-2000 series	Coinco - 478323 NV - 1579050
Mars VN2XX2-UXE (series 2000)	Mars - 250071009
Mars VN2XX2-UXM (series 2000)	Included with unit

# Snackvendor Models 170/171 Setup Guide

## 6. Set Up the Coin Mechanism

If the changer is not a MARS 6010 XV, proceed to *LOADING THE COIN MECHANISM*.

If the changer is a MARS 6010 XV, you must set the high quarter switch.

### SETTING THE QUARTER SWITCH:

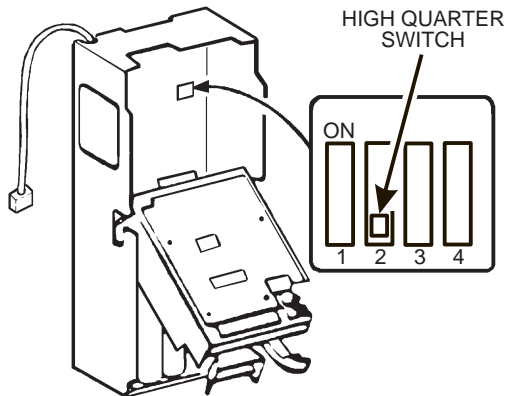

QUARTER SWITCH POSITION	ACTION
LOW	The coin mechanism will only store 6 quarters. The rest are sent to the coin box. Fewer quarters are available for change.
HIGH	The coin mechanism will store 69 quarters. More quarters are available for change.

## 7. Load the Coin Mechanism

1. Open the cabinet door.
2. Open the monetary door.
3. Insert coins one at a time until each of the coin tubes has been filled.
4. Inspect the tubes for shingled coins and correct if necessary.
5. Insert one coin of each type and verify that they are routed into the coin box. This verifies that the coin tubes are recognized as being full.

# Snackvendor Models 170/171 Setup Guide

## PROGRAMMING

### Getting Around

Getting around the Snackvendor software is pretty easy once you know the features that are available to you, and how to use them. The three main parts you will use are the SELECTION SWITCH PANEL, the DISPLAY, and the MODE switch.

### The Selection Switch Panel

The selection switch panel is located on the monetary panel. These are the keys customers use to make selections, but you will use these keys during programming procedures.

### Special Programming Keys

Some keys on the panel have jobs that only show up during programming. The keypad shown at right is what you will be using. To help you remember the keys, this panel will be shown on each page in the programming section.

- Ⓝ Press this key to move from one function to another.  
From within a function, press once to return to the beginning of the function; press and hold to return to the standby message.
- Ⓧ This key moves you around inside of a function.
- ⓕ This key allows you to switch between two or more choices.
- ⓓ This is the "action" key. It will start tests, etc.
- ⓐ This key is used to clear certain data or errors.

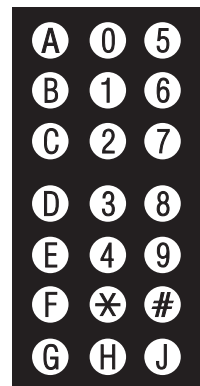

# Snackvendor Models 170/171 Setup Guide

## The Displays

The display group consists of a 4-character digital display which performs two functions, and is referred to in this book as "the display":



1. It shows the customer's selection and how much credit is in the machine, as well as the standby message.
2. It provides information and feedback to the service person during maintenance.

## Standby Messages

Two standard messages can be displayed under certain circumstances. These are called "Standby Messages". They are:

- .00 = This is the normal display. The numbers will change when credit is added.  
OUT OF ORdr = This is a fatal error - the machine will not run. See the error list.

The display group also contains two lamps which light up under certain conditions:

1. The "USE EXACT CHANGE" lamp lights when there are insufficient coins in the merchandiser to provide change for a vend. You can set the criteria for this condition in the programming section.
2. The "SELECTION PRICE" lamp lights when the customer has inserted insufficient credit into the machine to vend the selected product. In conjunction with this lamp lighting, the selection's price flashes in the digital display.

### NOTE

During programming modes, these lights blink whenever a key is pressed as a test of the lamps.

# Snackvendor Models 170/171 Setup Guide

## The MODE Switch

All programming procedures begin with this switch. Until you push the switch, the special programming keys will not work.

The MODE switch is a large square white button located on the rear of the controller board as shown.

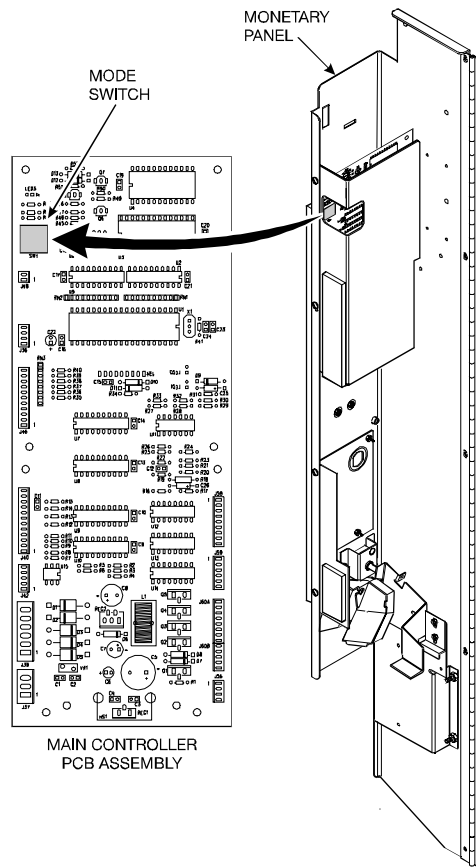

## Flowcharts

Think of a flowchart as a "roadmap" to the programming functions. Once you become familiar with the programming procedures, you can use the flowcharts as a quick reference.

The boxes represent the different functions, and the symbols between the boxes represent the keys you need to press in order to move between the functions.

# Snackvendor Models 170/171 Setup Guide

OVERALL PROGRAMMING FLOWCHART

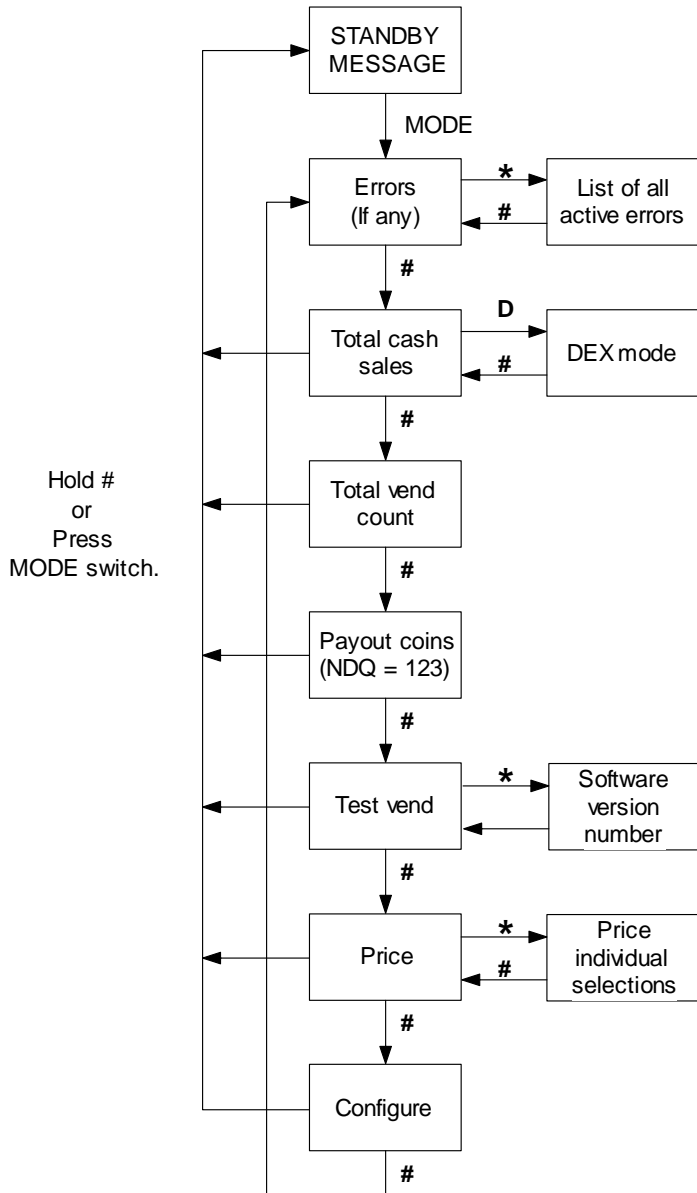

CONFIGURATION OPTIONS FLOWCHART

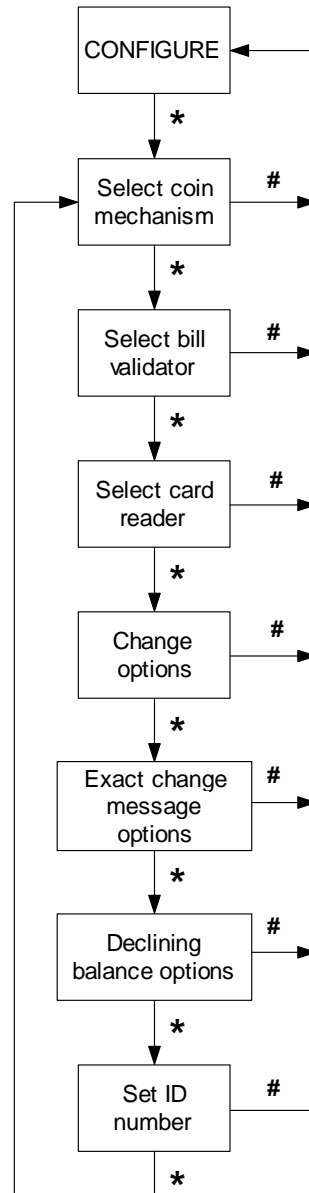



# Snackvendor Models 170/171 Setup Guide

## DATA

### NOTE

All data is not resettable.

1. Press the MODE switch on the main controller.
2. Press **#** until the display shows **CRSH**. The display will flash the total cash sales:  
**CRSH...XXXX...XX.XX**
3. If you have the DEX option, press **D** to transfer data into your DEX device.
4. Press **#**. The display shows **CFE**. The display will flash the total vend count:  
**CFE...XXXX...XXXX**
5. Press and hold **#** to return to the standby message.

## PAY OUT (Does not apply to machines with EXEC coin mechanisms.)

Pay out coins:

1. Press the MODE switch on the main controller.
2. Press **#** until the display shows **PAY**. Press **1** to pay out nickels, press **2** to pay out dimes, and press **3** to pay out quarters. Press **4** to pay out from the 4th MDB tubes.
3. Press the appropriate key once to pay out one coin.
4. Press and hold the appropriate key to pay out coins continuously.
5. Press and hold **#** to return to the standby message.

## PRICE

Set prices for all the selections in your merchandiser:

The price display: 

1. Press the MODE switch on the main controller.
2. Press **#** until the display shows **PRC**.
3. Press **\***, and the display shows **A0**, then **.XX**. "XX" is the price for selection A0.
4. Press **\*** until the selection you want to price is displayed, or press the letter and number of the selection.
5. Enter a new price with the number keys.
6. Repeat steps 4 and 5 until you have priced all the selections.  
**OR**
7. Press **#** to return to the **PRC** display, or hold **#** to exit.

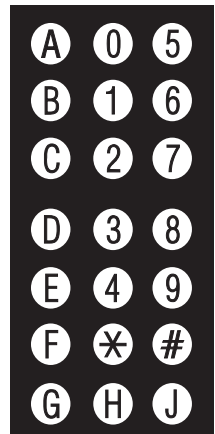

# Snackvendor Models 170/171 Setup Guide

## TEST

View machine status and test certain functions:

1. Press the MODE switch on the main controller.
2. Press **#** until the display shows **TEST**.
3. Make a selection (if you deposit money, the credit is shown in the display). After the product is delivered, your money is returned.

### NOTE

Test vends do not register in the **CASH** and **CNT** data.

4. Press and hold **#** to return to the standby message.

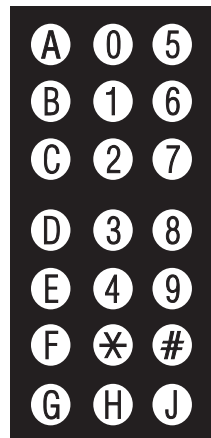

## FAULTS

Display all the active faults on your merchandiser:

1. Press the MODE switch on the main controller.
2. Press **#** until the display shows **Err**. **Note:** If no faults are present, this will not be displayed.
3. If errors are present, press **\*** to see the list of faults:

Err.03

The EPROM is bad.

Err.04

RAM is not initialized or is not compatible with the currently loaded software. If this message appears, initialize your RAM by performing the following procedure:

**NOTE: Initializing RAM will erase all your data. Be sure you have written this information down before continuing.**

Press AND HOLD **C**. You will see **CLR** in the display. Continue

holding until the display shows **DONE**.

Err.bL

Problem with the bill validator.

Err.Cd

Problem with the card reader.

Err.Cn

Problem with the coin mechanism.

NOSE...rdy

All selections are out of service.

Err.Pr

Illegal price is detected. Clear by checking prices.

*When the first fault item (if any) repeats, you have seen all the faults.*

4. Press **\*** to see more faults or **#** to exit.

# Setup and Programming Guide - Models 170/171

## CONFIGURE

Configure various machine functions:

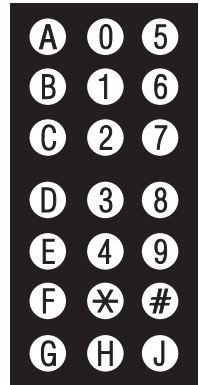

1. Press the MODE switch on the main controller.
2. Press **#** until the display shows .
3. Press **\***. The display shows the coin mechanism options:

**Cnd.** = dumb mech

**CnN.** = MDB

**CnE.** = Exec mech

**Cn0** . = No mech

Press **F** to switch between the coin mech choices.

4. Press **\***. The display shows the bill validator options:

**bL.P**= Pulse validator (not supported at this time)

**n.1.2.5** = MDB validator. Press **1**, **2**, or **5** to enable/disable acceptance of that denomination bill.

**n. d.** = MDB validator with additional bill selections

Press **D** to enter a list of bills. Two alternating screens appear:

**1. on** = Channel 1 and bill is enabled

**1.00** = Bill denomination

Press **F** to set bill acceptance ON or OFF

Press **\*** to scroll through the list of bills

Press **#** to move up to the top level screen when finished

**bL.0**= No validator

**cPn** = coupon bills

5. Press **\***. The display shows the card reader options:

**Cd.d** = Dumb

**Cd.n** = MDB

**Cd.0** = No card reader

6. Press **\***. The display shows **C.XX**. Change will be given for dollar coins or bills up to this amount without the customer having to make a selection. For example, if **1.00** is displayed, the machine will give the customer change for a dollar without requiring a selection. Entering **0.00** means that no change will be given.
7. Press **\***. The display shows: **EX.XX**. The customer will see the **USE EXACT CHANGE** lamp lighted when the amount of available change in the coin mechanism falls below the level you set for **X.XX**. Enter a value with the number keys. For example, if **E1.00** is selected, the customer sees the **USE EXACT CHANGE** lamp when less than a dollar's worth of change is in the coin mechanism.

## Setup and Programming Guide - Models 170/171

8. Press **(X)**. The display shows either:
  9. **db.on** = More than one vend is allowed, with a declining balance. This means that the customer can choose multiple products until the amount of credit is lower than the lowest priced product in the machine.

**OR**

**db.OF** = A declining balance is not allowed. Press **(F)** to switch between these two choices.
9. Press **(X)**. The display shows the machine ID number. This number is sent to a DEX device when transferring data.
10. If not present, enter the 6-digit machine ID number with the number keys. The number will fill in from the right.